

AC axial fan

straight blades (A series)

with guard grille for full nozzle

ebm-papst Mulfingen GmbH & Co. KG

Bachmühle 2 · D-74673 Mulfingen

Phone +49 7938 81-0

Fax +49 7938 81-110

info1@de.ebmpapst.com

www.ebmpapst.com

Limited partnership · Headquarters Mulfingen

Amtsgericht (court of registration) Stuttgart · HRA 590344

General partner Elektrobau Mulfingen GmbH · Headquarters Mulfingen

Amtsgericht (court of registration) Stuttgart · HRB 590142

Nominal data

Type	S2E300-BC47-01				
Motor	M2E068-EC				
Phase		1~	1~	1~	1~
Nominal voltage	VAC	230	230	230	230
Frequency	Hz	50	60	60	60
Method of obtaining data		fa	fa	fa	fa
Valid for approval/standard		CE	UL 2111	CSA	CE
Speed (rpm)	min ⁻¹	2650	2900	2900	2900
Power consumption	W	140	200	200	190
Current draw	A	0.62	0.88	0.88	0.83
Capacitor	µF	5	5	5	5
Capacitor voltage	VDB	400	400	400	400
Capacitor standard			S0 (CE)	UL	
Max. back pressure	Pa	150	150	150	150
Max. back pressure	in. wg	0.6	0.6	0.6	0.6
Min. ambient temperature	°C	-25	-25	-25	-25
Max. ambient temperature	°C	55	50	50	50

ml = Max. load · me = Max. efficiency · fa = Free air · cs = Customer specification · ce = Customer equipment
Subject to change

Data according to Commission Regulation (EU) 327/2011 (EN 17166)

		Actual	Req. 2015		
01 Overall efficiency η_{es}	%	32.2	28.7	09 Power consumption P_e	kW
02 Measurement category	A			09 Air flow q_v	m ³ /h
03 Efficiency category	Static			09 Pressure increase p_{fs}	Pa
04 Efficiency grade N	43.5	40		10 Speed (rpm) n	min ⁻¹
05 Variable speed drive	No			11 Specific ratio*	1.00

Data obtained at optimum efficiency level.

The ErP data is determined using a motor-impeller combination in a standardized measurement setup.

* Specific ratio = $1 + p_{fs} / 100\,000\text{ Pa}$

LU-199188



AC axial fan

straight blades (A series)
with guard grille for full nozzle

Technical description

Weight	3.2 kg
Size	300 mm
Motor size	68
Rotor surface	Painted black
Blade material	Sheet steel, painted black
Guard grille material	Steel, coated with black plastic (RAL 9005)
Number of blades	5
Airflow direction	V
Direction of rotation	Counterclockwise, viewed toward rotor
Degree of protection	IP44; installation- and position-dependent as per EN 60034-1
Insulation class	"B"
Moisture (F) / Environmental (H) protection class	H1
Max. permitted ambient temp. for motor (transport/storage)	+ 80 °C
Min. permitted ambient temp. for motor (transport/storage)	- 40 °C
Installation position	Shaft horizontal or rotor on bottom; rotor on top on request
Condensation drainage holes	On rotor side
Mode	S1
Motor bearing	Ball bearing
Touch current according to IEC 60990 (measuring circuit Fig. 4, TN system)	< 0.75 mA
Motor protection	Thermal overload protector (TOP) internally connected
With cable	Variable
Protection class	I (with customer connection of protective earth)
Conformity with standards	EN 60335-1; CE
Approval	EAC



AC axial fan

straight blades (A series)

with guard grille for full nozzle

Product drawing

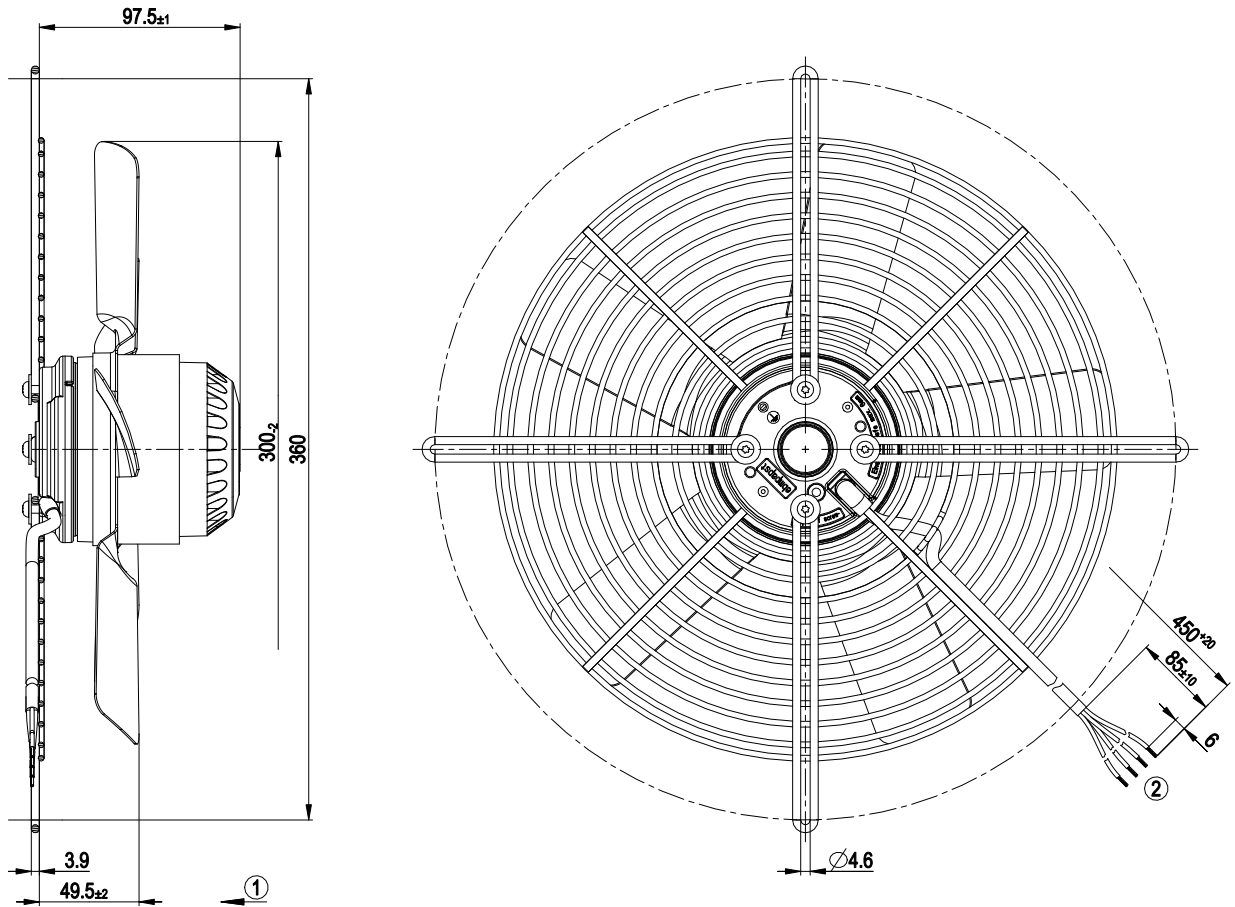

- 1 Direction of air flow "V"
- 2 Cable PVC 4G 0.5 mm², 4x crimped splices

Connection diagram

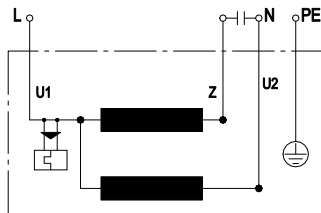

U1	blue	Z	brown	U2	black
PE	green/yellow				



AC axial fan

straight blades (A series)
with guard grille for full nozzle

Curves: Air performance 50 Hz

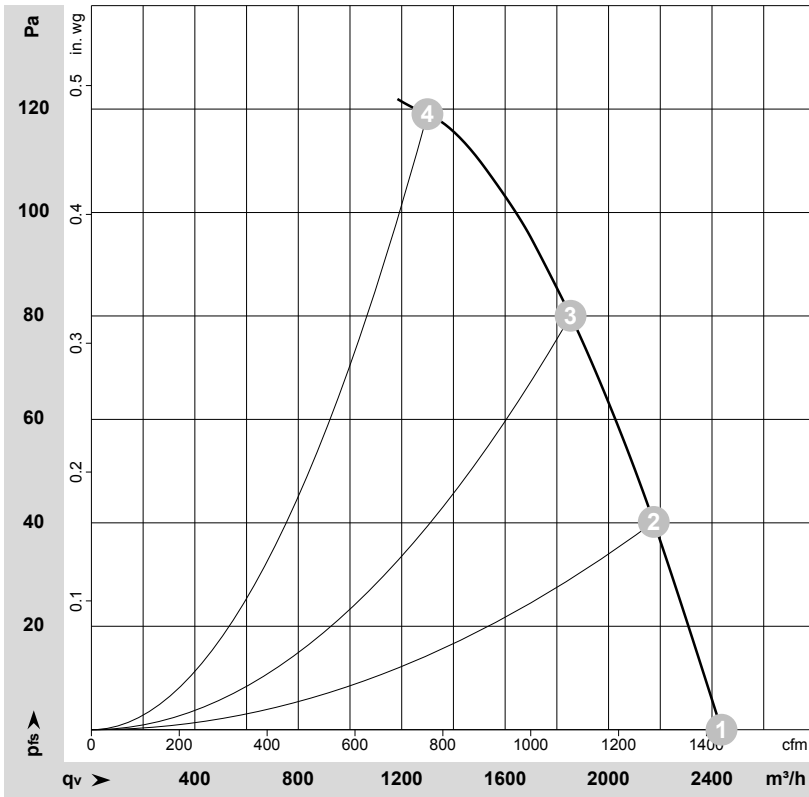

$\rho = 1.15 \text{ kg/m}^3 \pm 2 \%$

Measurement: LU-66600-1

Air performance measured according to ISO 5801 installation category A. For detailed information on the measurement setup, contact ebmpapst. Intake sound level: Sound power level according to ISO 13347 / sound pressure level measured at 1 m distance from fan axis. The values given are valid under the specified measuring conditions and may vary due to conditions of installation. For deviations from the standard configuration, the parameters have to be checked on the installed unit.

Measured values

	Wired	U	f	n	P _e	I	q _v	P _{fs}	q _v	P _{fs}
		V	Hz	min ⁻¹	W	A	m ³ /h	Pa	cfm	in. wg
1	1~	230	50	2650	140	0.62	2435	0	1435	0.00
2	1~	230	50	2610	151	0.66	2175	40	1280	0.16
3	1~	230	50	2580	158	0.69	1855	80	1090	0.32
4	1~	230	50	2565	161	0.70	1300	120	765	0.48

Wired = Wiring · U = Voltage · f = Frequency · n = Speed (rpm) · P_e = Power consumption · I = Current draw · q_v = Air flow · P_{fs} = Pressure increase



AC axial fan

straight blades (A series)

with guard grille for full nozzle

Curves: Air performance 60 Hz

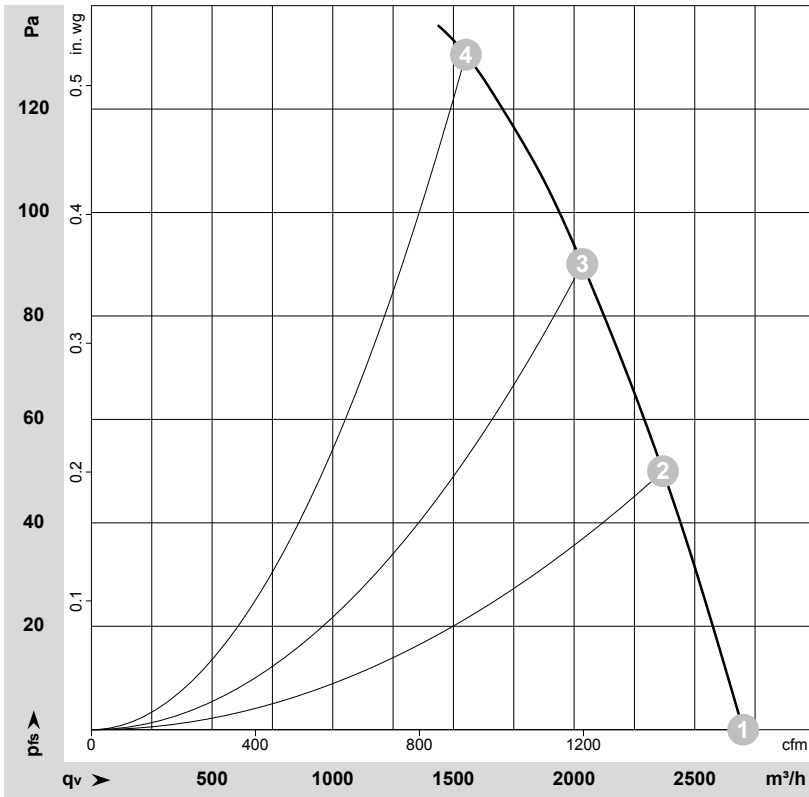

$\rho = 1.15 \text{ kg/m}^3 \pm 2 \%$

Measurement: LU-66601-1

Air performance measured according to ISO 5801 installation category A. For detailed information on the measurement setup, contact ebm-papst. Intake sound level: Sound power level according to ISO 13347 / sound pressure level measured at 1 m distance from fan axis. The values given are valid under the specified measuring conditions and may vary due to conditions of installation. For deviations from the standard configuration, the parameters have to be checked on the installed unit.

Measured values

	Wired	U	f	n	P _e	I	q _v	P _{fs}	q _v	P _{fs}
		V	Hz	min ⁻¹	W	A	m ³ /h	Pa	cfm	in. wg
1	1~	230	60	2900	190	0.83	2700	0	1590	0.00
2	1~	230	60	2860	205	0.90	2370	50	1395	0.20
3	1~	230	60	2800	213	0.93	2035	90	1195	0.36
4	1~	230	60	2750	218	0.95	1550	130	915	0.52

Wired = Wiring · U = Voltage · f = Frequency · n = Speed (rpm) · P_e = Power consumption · I = Current draw · q_v = Air flow · P_{fs} = Pressure increase

