

sickle-shaped blades (S series)

with square full nozzle

ebm-papst Mulfingen GmbH & Co. KG

Bachmühle 2 · D-74673 Mulfingen

Phone +49 7938 81-0

Fax +49 7938 81-110

info1@de.ebmpapst.com

www.ebmpapst.com

Limited partnership · Headquarters Mulfingen

Amtsgericht (court of registration) Stuttgart · HRA 590344

General partner Elektrobau Mulfingen GmbH · Headquarters Mulfingen

Amtsgericht (court of registration) Stuttgart · HRB 590142

Nominal data

Type	W3G800-KU21-03	
Motor	M3G150-IF	
Phase		3~
Nominal voltage	VAC	400
Nominal voltage range	VAC	380 .. 480
Frequency	Hz	50/60
Method of obtaining data		ml
Speed (rpm)	min ⁻¹	1080
Power consumption	W	2900
Current draw	A	4.4
Max. back pressure	Pa	300
Max. back pressure	in. wg	1.2
Min. ambient temperature	°C	-25
Max. ambient temperature	°C	60

ml = Max. load · me = Max. efficiency · fa = Free air · cs = Customer specification · ce = Customer equipment
Subject to change

Data according to Commission Regulation (EU) 327/2011

		Actual	Req. 2015
01 Overall efficiency η_{es}	%	50.1	36.3
02 Measurement category		A	
03 Efficiency category		Static	
04 Efficiency grade N		53.8	40
05 Variable speed drive		Yes	

Data obtained at optimum efficiency level.

The ErP data is determined using a motor-impeller combination in a standardized measurement setup.

09 Power consumption P_{ed}	kW	2.61
09 Air flow q_v	m ³ /h	19180
09 Pressure increase p_{fs}	Pa	233
10 Speed (rpm) n	min ⁻¹	1080
11 Specific ratio*		1.00

* Specific ratio = $1 + p_{fs} / 100\,000\text{ Pa}$

LU-185100



Technical description

Weight	47.5 kg
Size	800 mm
Motor size	150
Rotor surface	Painted black
Electronics housing material	Die-cast aluminum, painted gray
Impeller material	PP plastic
Fan housing material	Sheet steel, galvanized and coated with black plastic (RAL 9005)
Guard grille material	Steel, coated with black plastic (RAL 9005)
Number of blades	5
Blade pitch	0°
Airflow direction	V
Direction of rotation	Clockwise, viewed toward rotor
Degree of protection	IP55
Insulation class	"F"
Moisture (F) / Environmental (H) protection class	H2
Ambient temperature note	Occasional start-up between -40°C and -25°C is permissible. For continuous operation at temperatures below -25°C (e.g. refrigeration applications) we recommend our fan design with special low-temperature bearings.
Max. permitted ambient temp. for motor (transport/storage)	+ 80 °C
Min. permitted ambient temp. for motor (transport/storage)	- 40 °C
Installation position	Shaft horizontal or rotor on bottom; rotor on top on request
Condensation drainage holes	On rotor side
Mode	S1
Motor mounting	Ball bearing
Technical features	<ul style="list-style-type: none"> - Operation and fault indication via LED - External 15-50 VDC input (parameterization) - Alarm relay - Integrated PI controller - Configurable inputs/outputs (I/O) - MODBUS V6 - Motor current limitation - RFID - ISO 15693 compatible - RS485 MODBUS-RTU - Soft start - EEPROM write cycles max. 100,000 - Voltage output 3.3-24 VDC, Pmax = 800 mW - Control interface with SELV potential safely disconnected from supply - Thermal overload protection for electronics/motor - Undervoltage/phase failure detection
Touch current according to IEC 60990 (measuring circuit Fig. 4, TN system)	<= 3.5 mA
Electrical hookup	Terminal box
Motor protection	Reverse polarity and locked-rotor protection
Protection class	I (with customer connection of protective earth)
Conformity with standards	EN 61800-5-1; CE

W3G800-KU21-03

EC axial fan - AxiBlade

sickle-shaped blades (S series)

with square full nozzle

Approval

EAC; CSA C22.2 No. 77 + CAN/CSA-E60730-1; UL 1004-7 + 60730



EC axial fan - AxiBlade

sickle-shaped blades (S series)

with square full nozzle

Product drawing

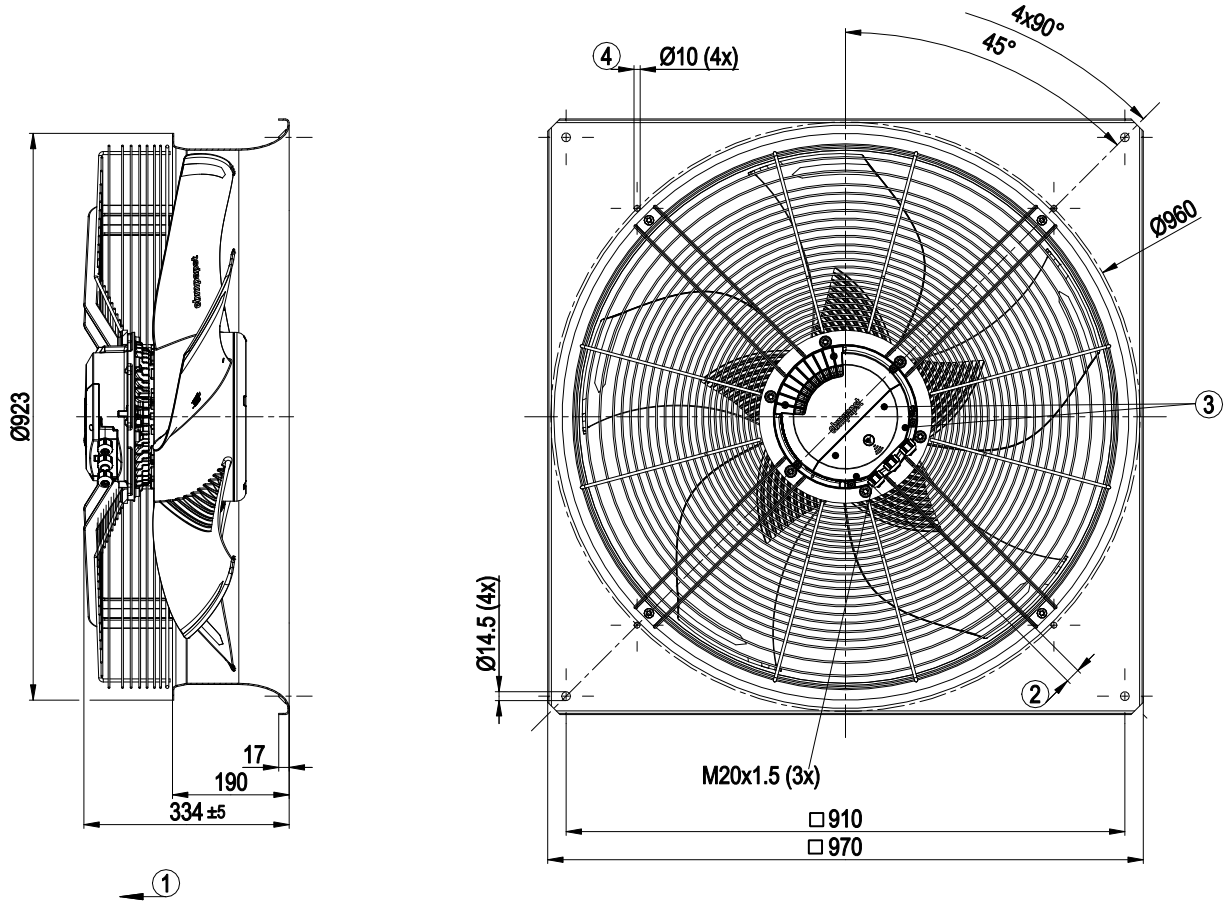

1	Airflow direction "V"
2	Cable diameter min. 4 mm, max. 10 mm, tightening torque 2 ± 0.3 Nm
3	Tightening torque 1.5 ± 0.2 Nm
4	Mounting holes for FlowGrid



EC axial fan - AxiBlade

sickle-shaped blades (S series)
with square full nozzle

Connection diagram

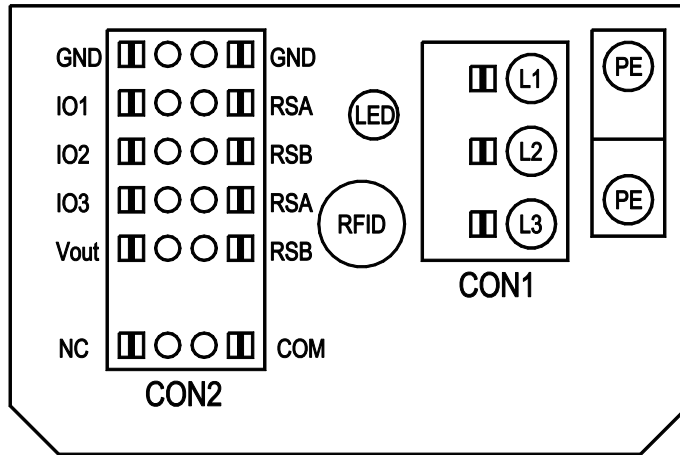

No.	Conn.	Designation	Function/assignment
CON1	-	L1, L2, L3	Supply connection, power supply, protection class 1
PE	-	PE	Ground connection, PE connection
CON2	-	RSA	Bus connection RS485, RSA, MODBUS-RTU; SELV
CON2	-	RSB	Bus connection RS485, RSB, MODBUS-RTU; SELV
CON2	-	GND	GND reference ground for control interface, SELV
CON2	-	IO1	IN2: Digital input - positive logic (factory setting: Enable) function parameterizable, SELV - normal: Pin open or applied voltage < 1.5 VDC - inverse: applied voltage 3.5-50 VDC
CON2	-	IO2	IN1: Analog input 0-10 V 0-10 V, Ri=100 K, parameterizable as set value or measured value (factory setting: set value) characteristic curve parameterizable, SELV
CON2	-	IO3	OUT1: Analog output 0-10 V 0-10 V, max 5 mA, function parameterizable (factory setting: modulation level) max output frequency 300 Hz, SELV
CON2	-	V out	Voltage output 3.3-24 VDC +/-5%, Pmax=800 mW, voltage parameterizable (factory setting: 10 VDC) short-circuit-proof, supply for external devices, SELV alternatively: 15-50 VDC input for parameterization via Modbus without line voltage
CON2	-	COM	Status relay, floating status contact; common connection, nominal voltage 250 VAC; max 2 A (AC1): min 10 mA; Reinforced insulation in accordance with EN60335-1, EN61800-5-1, UL60730-1
CON2	-	NC	Status relay, floating status contact, break for failure



EC axial fan - AxiBlade

sickle-shaped blades (S series)

with square full nozzle

Curves: Air performance 50 Hz

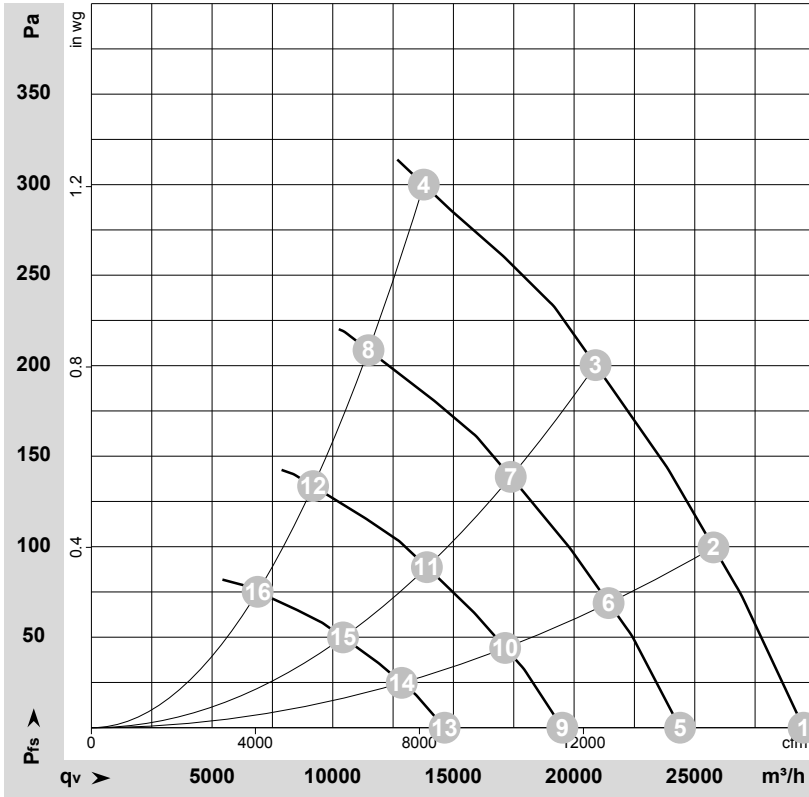

$\rho = 1.15 \text{ kg/m}^3 \pm 2 \%$

Measurement: LU-185100-1

Air performance measured according to ISO 5801 installation category A. For detailed information on the measurement setup, contact ebmpapst. Intake sound level: Sound power level according to ISO 13347 / sound pressure level measured at 1 m distance from fan axis. The values given are valid under the specified measuring conditions and may vary due to conditions of installation. For deviations from the standard configuration, the parameters have to be checked on the installed unit.

Measured values

	U	f	n	P _{ed}	I	LpA _{in}	LwA _{in}	LwA _{out}	q _v	P _{fs}	q _v	P _{fs}
	V	Hz	min ⁻¹	W	A	dB(A)	dB(A)	dB(A)	m ³ /h	Pa	cfm	in. wg
1	400	50	1080	1754	2.77	72	79	81	29510	0	17370	0.00
2	400	50	1080	2139	3.34	70	78	79	25775	100	15170	0.40
3	400	50	1080	2489	3.85	75	82	82	20890	200	12295	0.80
4	400	50	1080	2900	4.40	85	93	94	13770	300	8105	1.20
5	400	50	900	990	1.56	67	75	77	24390	0	14355	0.00
6	400	50	900	1230	1.92	66	73	75	21430	69	12615	0.28
7	400	50	900	1433	2.22	70	77	78	17375	139	10225	0.56
8	400	50	900	1656	2.55	81	88	89	11480	209	6760	0.84
9	400	50	720	507	0.80	62	69	71	19515	0	11485	0.00
10	400	50	720	630	0.98	60	68	69	17145	44	10090	0.18
11	400	50	720	733	1.13	64	71	72	13900	89	8180	0.36
12	400	50	720	848	1.30	75	83	84	9185	133	5405	0.53
13	400	50	540	214	0.34	54	62	64	14635	0	8615	0.00
14	400	50	540	266	0.41	53	60	62	12860	25	7570	0.10
15	400	50	540	309	0.48	57	64	65	10425	50	6135	0.20
16	400	50	540	358	0.55	68	75	76	6890	75	4055	0.30

U = Power supply · f = Frequency · n = Speed (rpm) · P_{ed} = Power consumption · I = Current draw · LpA_{in} = Sound pressure level intake side · LwA_{in} = Sound power level intake side
LwA_{out} = Sound power level outlet side · q_v = Air flow · P_{fs} = Pressure increase

