

DUCT FANS



BDTX

AC CENTRIFUGAL IN LINE DUCT FANS Backward Curved

Straight airflow and easy installation - with the high pressure stability, low noise level and high efficiency. Both sides of the BDTX fans is suitable to fit into the centrifugal duct and can be fixed with fastening clamps. Fans can be performed in any mounting position.

Technical Drawings

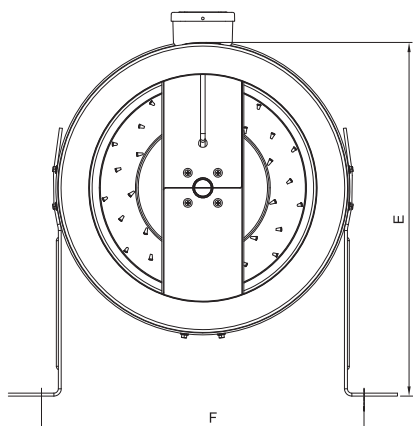
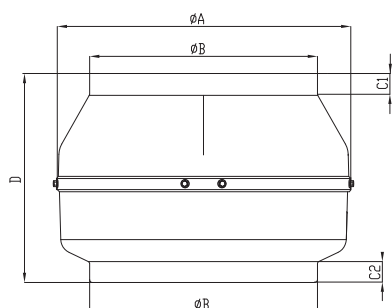

- MATERIAL** : The housing is made of electrostatic powder coated sheet iron, impeller is made of galvanized sheet metal. Housing forming is proceeded by stamps for proper fit.
- INSULATION CLASS** : Class B, Class F
- DIRECTIVE** : EN 60335-1, EN 60335-2-80
- PROTECTION OF MOTOR** : Thermal overload protection is available upon request. (Connector box- IP 55)
- SPEED CONTROL** : Speed can be adjusted using an optional controller.
- APPLICATION AREAS** : For industrial and constructional applications, in factories, hospitals, night clubs, offices, kitchens, bathrooms, theaters, condominiums, restaurants, etc.



TYPE	A	B	C1	C2	D	E	F
BDTX 100	245	97	22	22	197	273	268
BDTX 125	245	122	20	20	188	273	268
BDTX 150B	272	147	23	25	192	286	295
BDTX 160A	272	157	23	25	192	286	295
BDTX 200A	330	196	30	28	230	380	352
BDTX 200B	330	196	30	28	230	380	352
BDTX 250A	330	247	30	28	227	380	352
BDTX 250B	330	247	30	28	227	380	352
BDTX 315A	400	313	30	30	285	415	422
BDTX 315B	400	313	30	30	285	415	422
BDTX 355	400	352	30	30	378	415	422

Dimensions are in (mm)

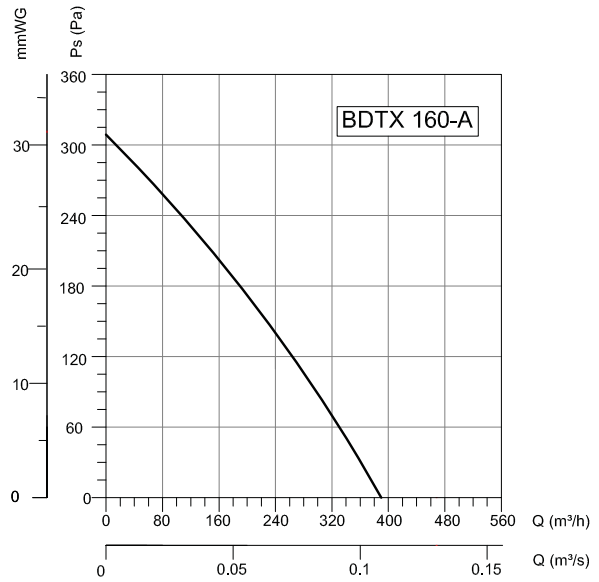
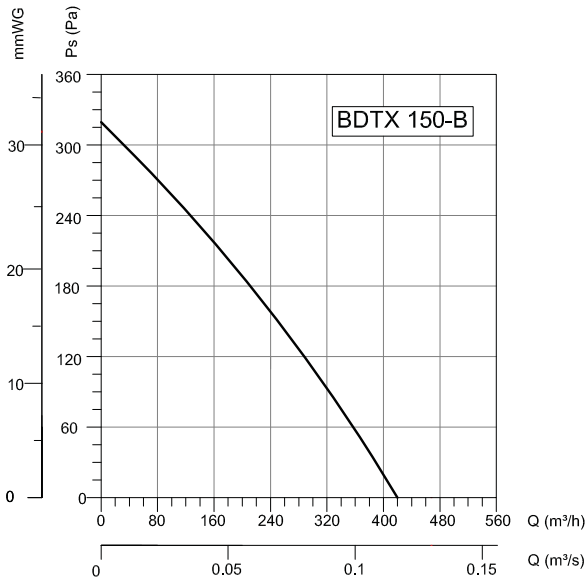
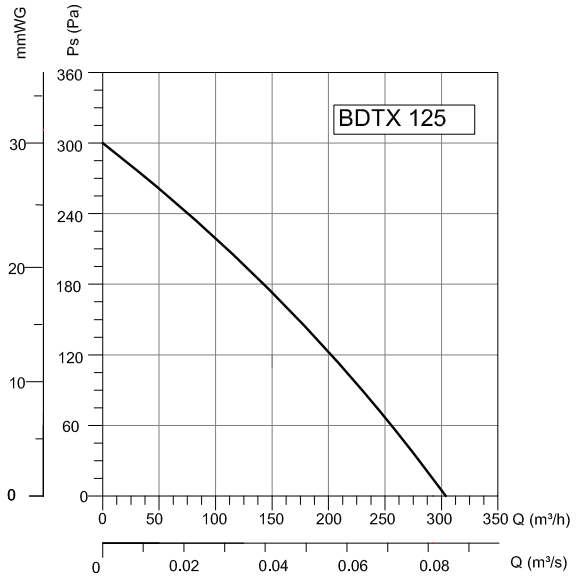
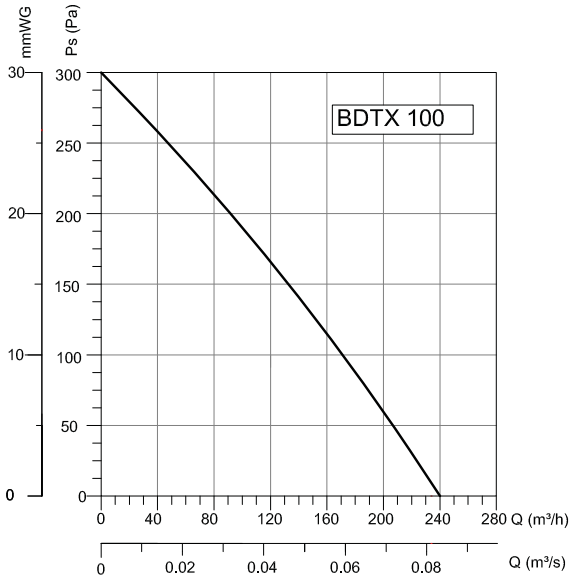

TYPE	VOLTAGE	FREQUENCY	POWER	CURRENT	CAPACITOR	SPEED	AIR FLOW	SOUND PRESSURE LEVEL	WEIGHT
	V	Hz	W	(A)	(μ F)	d/d	m ³ /h	dB(A)	kg
BDTX 100	230	50	80	0,3	2	2610	240	50	2,6
BDTX 125	230	50	80	0,36	2,5	2325	315	55	2,7
BDTX 150-B	230	50	85	0,38	2,5	2425	420	55	3,2
BDTX 160-A	230	50	90	0,4	2,5	2385	390	55	3
BDTX 200-A	230	50	95	0,43	2,5	2280	735	55	4,4
BDTX 200-B	230	50	122	0,55	4	2550	870	56	4,8
BDTX 250-A	230	50	124	0,56	4	2500	1010	57	4,9
BDTX 250-B	230	50	145	0,63	5	2635	1150	58	5,3
BDTX 315-A	230	50	190	0,9	5	2560	1450	65	6,8
BDTX 315-B	230	50	210	1,1	7	2660	1750	65	6,9
BDTX 355	230	50	123	0,63	4	1420	1300	66	9

DUCT FANS

ROOF FANS

AXIAL FANS

RADIAL FANS

PLASTIC FANS

VENTILATORS

SMOKE EXHAUST SYSTEMS

ACCESSORIES

DUCT FANS

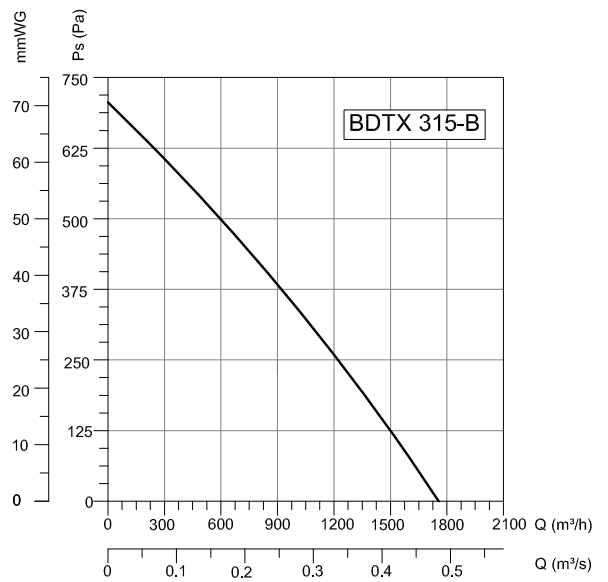
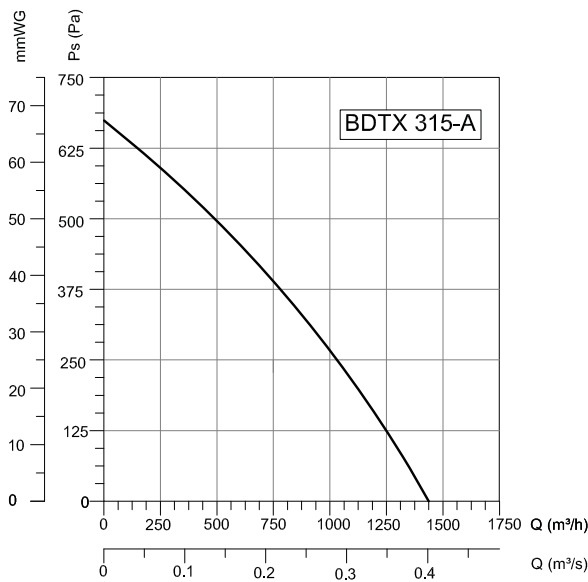
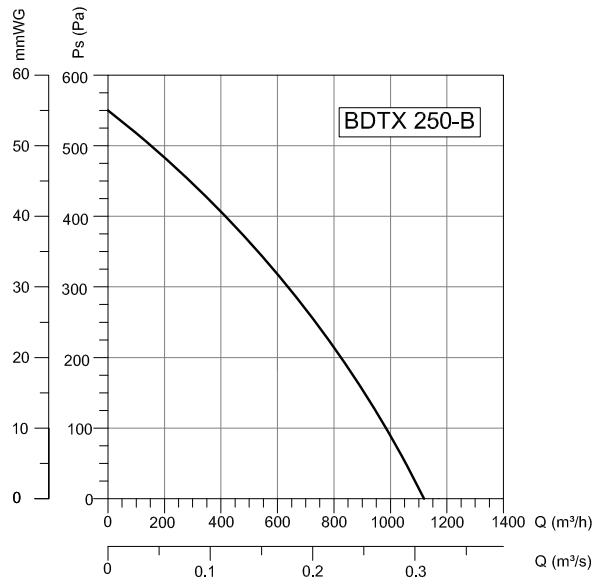
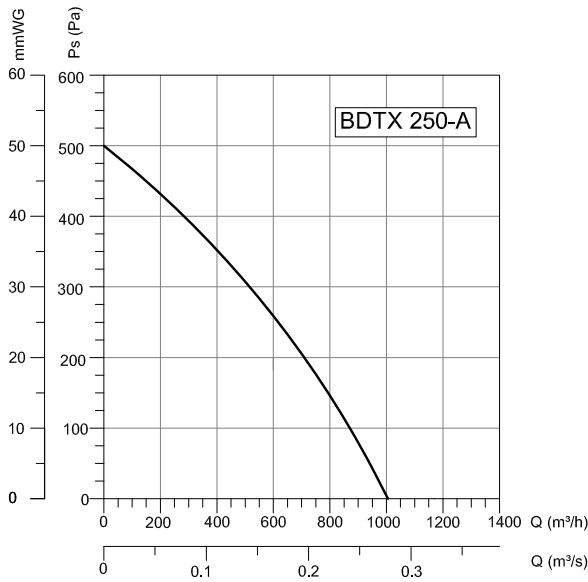
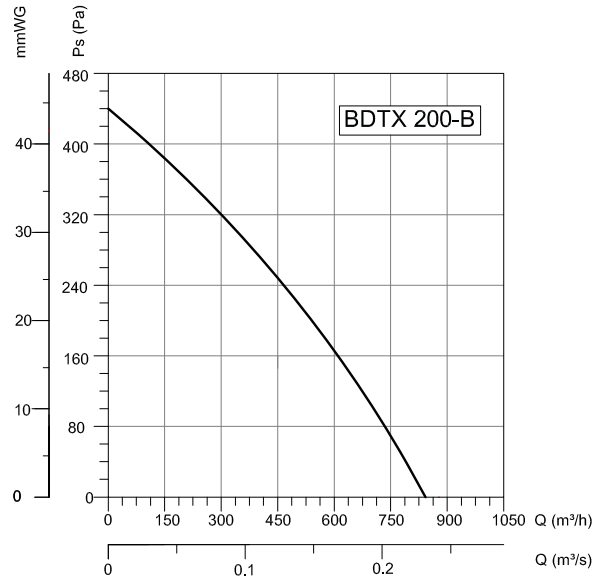
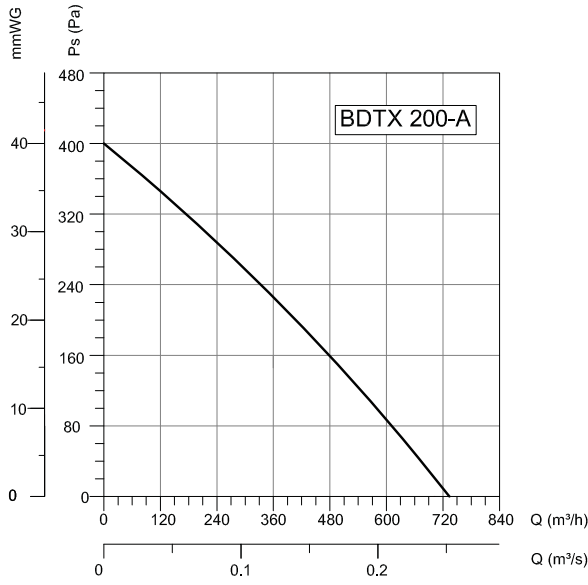

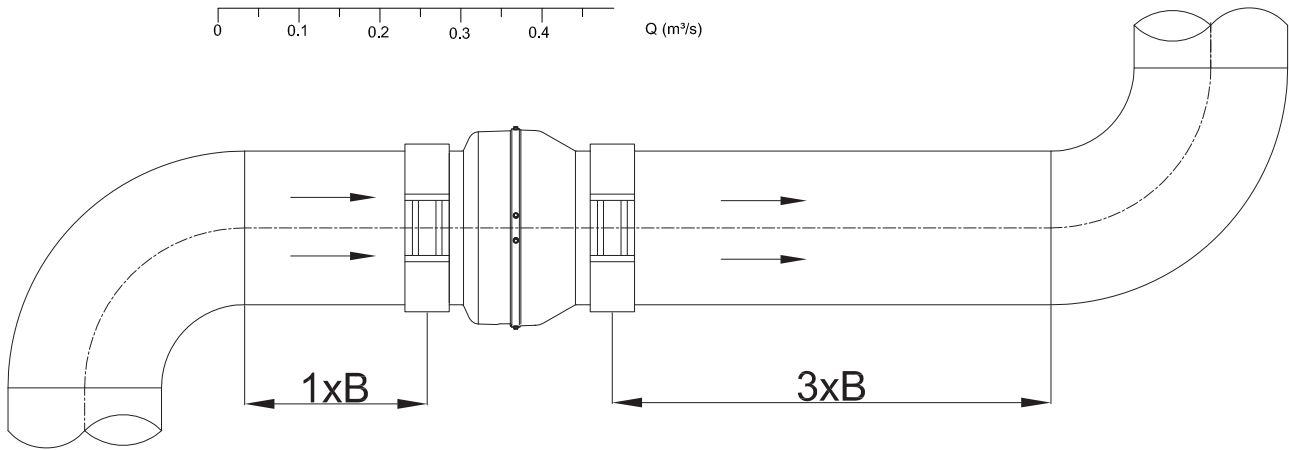
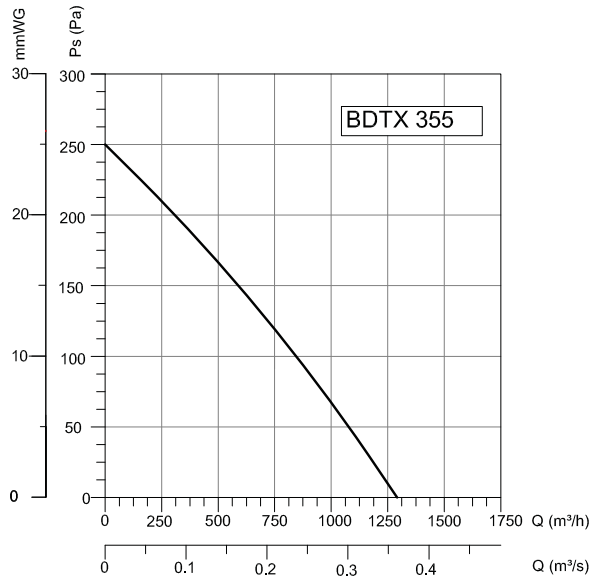

- DUCT FANS
- ROOF FANS
- AXIAL FANS
- RADIAL FANS
- PLASTIC FANS
- VENTILATORS
- SMOKE EXHAUST SYSTEMS
- ACCESSORIES



BMFX

ROUND DUCT TYPE FANS / Mixed Flow

Device Components and Material Properties

Duct type mixed flow fans, ST extension models are standard. Body and fan made of plastic. BMFX 250 and 315 models are also available with electrostatic painted sheet version. Thanks to the body design, it is possible to disassemble and install the fan and motor without being disassembled.

Fan Structure

Mixed flow fans consist of a combination of working principles of axial and casing centrifugal fans. These fans draw air in and out more linearly. This makes the system more efficient and reduces motor power.

Benefits

They are highly efficient due to the mixed flow propeller. They work pretty quietly. When the fan is connected to the duct, the motor part can be easily removed and installed. They can work in double cycle. The suction and discharge nozzles are compatible with the duct diameters and can be connected by clamp.

Speed Control

Optional control devices can be provided.
* Double speed motor * Speed control with linear voltage regulator (see BSC accessory)

Usage Areas

It is used for return air, supply air or general ventilation applications where low noise level and high efficiency are important. It should be used with oil holding filter in oily environments.

Technical Drawing and Tables

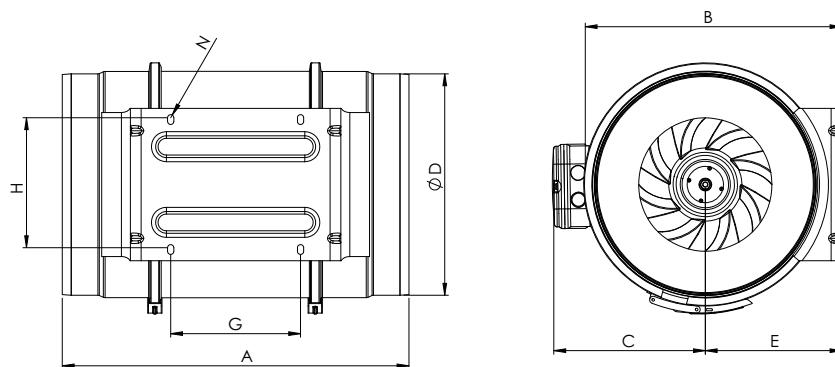

TYPE	A	B	C	D	E	G	H	N
BMFX-100	303	188	115	97	100	80	60	5,5
BMFX-125	258	188	115	123	100	80	60	5,5
BMFX-150	320	212	127	147	112	80	60	5,5
BMFX-200	302	232,5	141	197	124	100	94	5,5
BMFX-250	386	291	192	248	155	145	140	7X4
BMFX-315	450	356	224	312	188	182	178	7X4
BMFX-250-P	383	286	173	247	151	150	173	7X4
BMFX-315-P	446	357	216	312	187	181	216	7X4

Dimensions are in (mm)

TYPE	A	ØB	ØD	E	F	G	X	C	ØH
BMFX-ST100	460	204	23	81	248	333	222	93	98
BMFX-ST125	460	204	23	81	248	333	222		

Dimensions are in (mm)

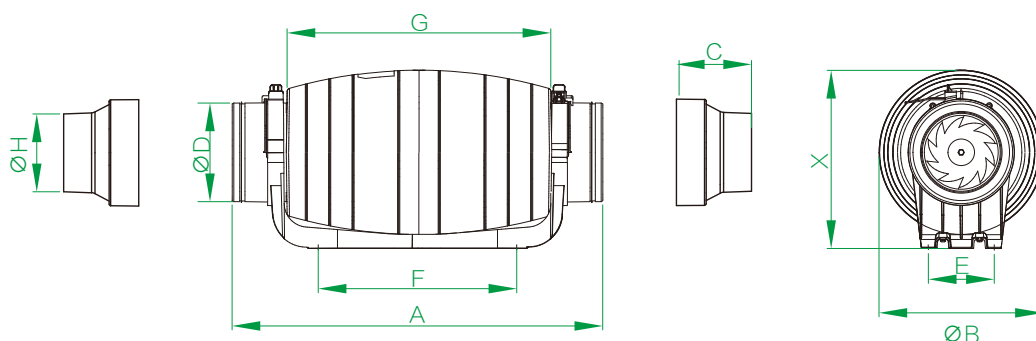

TYPE	VOLTAGE	FREQUENCY	POWER	CURRENT	CAPACITOR	SPEED	AIR FLOW	SOUND PRESSURE	INSULATION CLASS	PROTECTION CLASS	WEIGHT	SPEED
	V	Hz	W	(A)	(μ F)	r.p.m	m ³ /h	dB(A)	Ins.cl.	IP	kg	
BMFX 100/2V	230	50/60	20	0,11	1	2200	198	31	B	44	1,8	H
			18	0,10		1850	165	26				L
BMFX 125/2V	230	50/60	27	0,14	1	2250	284	31	B	44	2	H
			23	0,12		1950	248	26				L
BMFX 150/2V	230	50/60	44	0,22	1,2	2550	530	33	B	44	2,7	H
			35	0,19		1950	410	29				L
BMFX 200/2V	230	50/60	100	0,52	3	2350	840	36	B	44	4,8	H
			90	0,48		2050	690	32				L
BMFX 250/2V	230	50/60	140	0,7	5	2500	1100	40	F	44	9,4	H
			110	0,6		2050	990	37				L
BMFX 315/2V	230	50/60	190	1,1	10	2680	2000	45	F	44	14	H
			145	0,74		2150	1500	40				L
BMFX 250-P/2V	230	50/60	225	1,2	8	2450	1405	38	B	44	7,5	H
			165	0,75		1850	1064	34				L
BMFX 315-P/2V	230	50/60	390	1,9	16	2350	2206	42	B	44	11	H
			275	1,4		1650	1750	38				L
BMFX-ST 100/2V	230	50/60	35	0,26	1	2600	177	25	B	44	3	H
			20	0,15		2100	133	23				L
BMFX-ST 125/2V	230	50/60	35	0,28	1	2600	218	31	B	44	3,5	H
			20	0,17		2100	181	26				L

Sound Level Measured from 3m distance in room condition.

Accessories



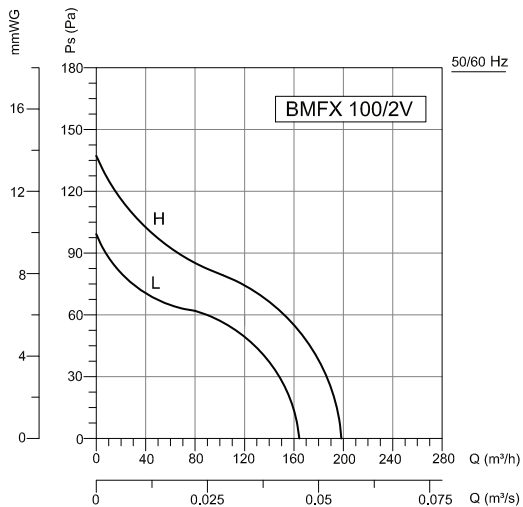

Frequency	Tot	63	125	250	500	1000	2000	4000	8000	Hz
L_{WA} Inlet	58	29	48	46	54	53	48	40	34	dB(A)
L_{WA} Surrounding	52	28	47	46	45	44	44	33	26	dB(A)

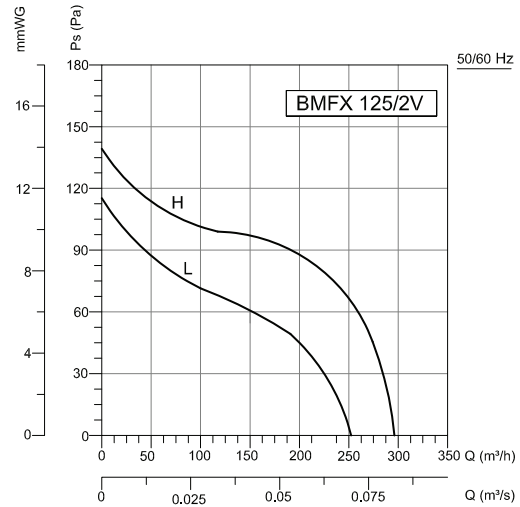

Frequency	Tot	63	125	250	500	1000	2000	4000	8000	Hz
L_{WA} Inlet	56	33	45	44	51	52	48	39	31	dB(A)
L_{WA} Surrounding	51	31	44	44	45	45	43	31	22	dB(A)

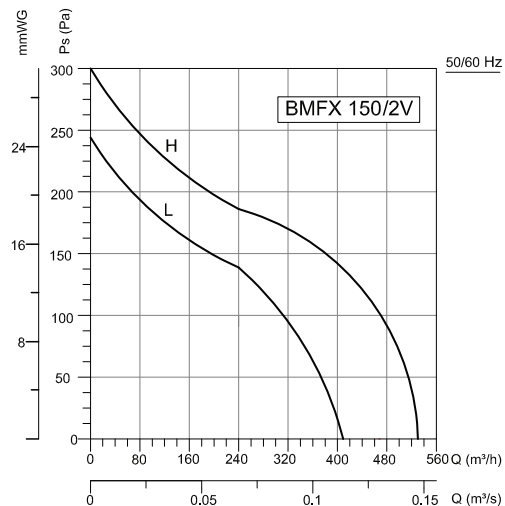

Frequency	Tot	63	125	250	500	1000	2000	4000	8000	Hz
L_{WA} Inlet	65	33	35	55	56	59	60	56	47	dB(A)
L_{WA} Surrounding	54	25	32	43	39	44	53	42	29	dB(A)

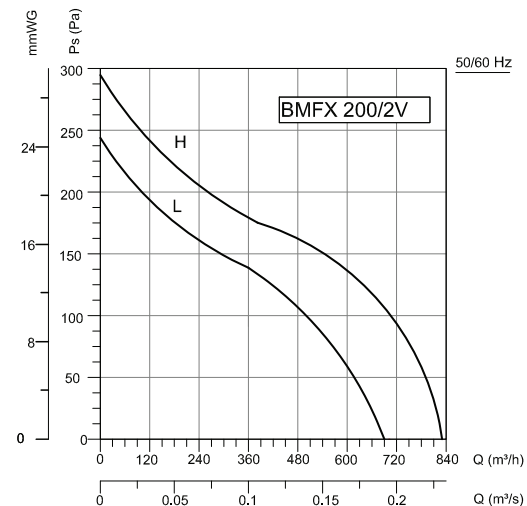

Frequency	Tot	63	125	250	500	1000	2000	4000	8000	Hz
L_{WA} Inlet	69	34	44	58	60	65	64	61	51	dB(A)
L_{WA} Surrounding	57	26	33	44	43	51	54	45	30	dB(A)

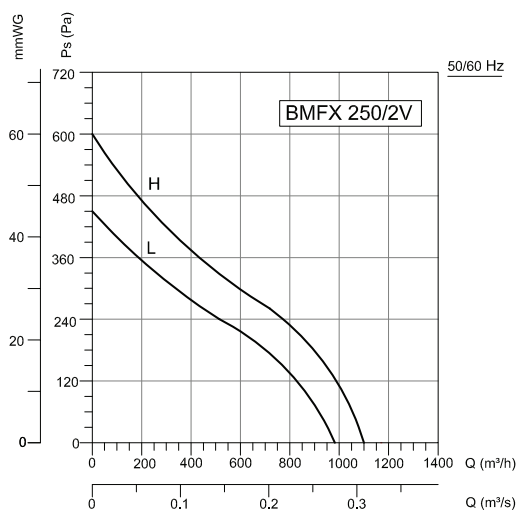

Frequency	Tot	63	125	250	500	1000	2000	4000	8000	Hz
L_{WA} Inlet	75	33	46	58	66	72	69	62	55	dB(A)
L_{WA} Surrounding	61	25	35	45	46	58	57	47	43	dB(A)

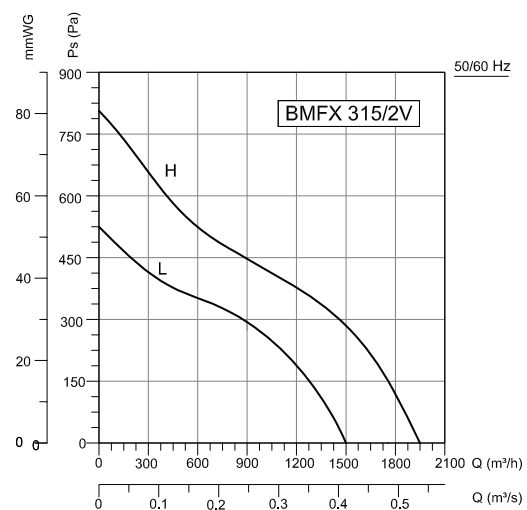

Frequency	Tot	63	125	250	500	1000	2000	4000	8000	Hz
L_{WA} Inlet	75	38	54	63	68	74	41	54	59	dB(A)
L_{WA} Surrounding	65	26	38	49	52	61	60	54	50	dB(A)

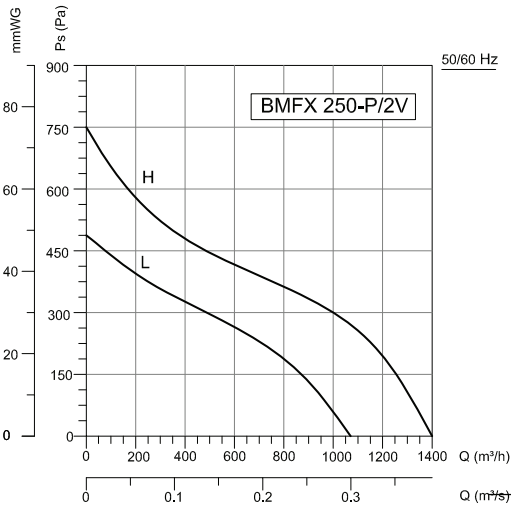

Frequency	Tot	63	125	250	500	1000	2000	4000	8000	Hz
L_{WA} Inlet	73	31	44	56	64	70	67	60	53	dB(A)
L_{WA} Surrounding	59	23	33	43	44	56	55	45	41	dB(A)

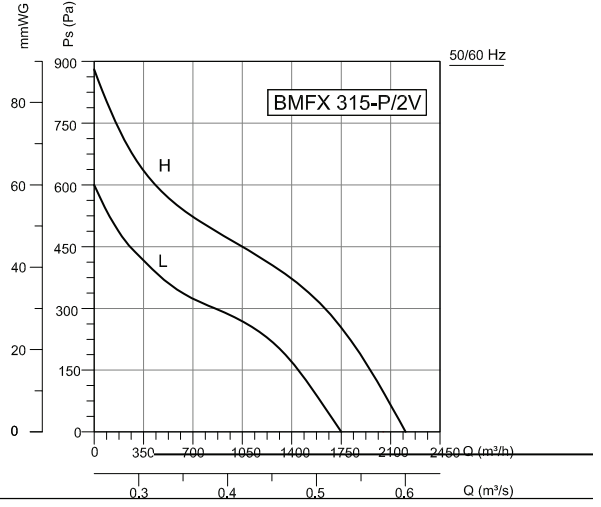

Frequency	Tot	63	125	250	500	1000	2000	4000	8000	Hz
L_w A Inlet	74	36	52	61	68	72	39	52	57	dB(A)
L_{WA} Surrounding	63	24	36	47	50	59	58	52	48	dB(A)

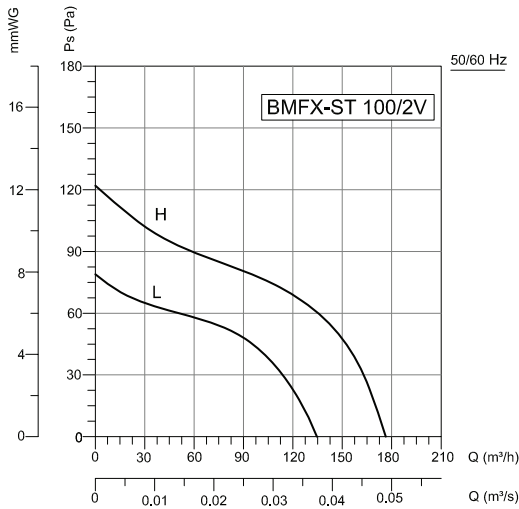

Frequency	Tot	63	125	250	500	1000	2000	4000	8000	Hz
L_{WA} Inlet	56	33	45	44	51	52	48	39	31	dB(A)
L_{WA} Surrounding	51	31	44	44	45	45	43	31	22	dB(A)

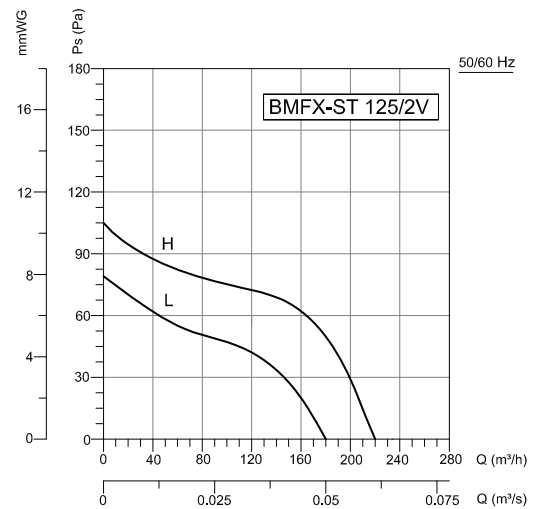

Frequency	Tot	63	125	250	500	1000	2000	4000	8000	Hz
L_{WA} Inlet	56	33	45	44	51	52	48	39	31	dB(A)
L_{WA} Surrounding	51	31	44	44	45	45	43	31	22	dB(A)