

ebm-papst Mulfingen GmbH & Co. KG
 Bachmühle 2
 D-74673 Mulfingen
 Phone +49 (0) 7938 81-0
 Fax +49 (0) 7938 81-110
 info1@de.ebmpapst.com
 www.ebmpapst.com

CONTENTS

1. SAFETY REGULATIONS AND NOTES	1
1.1 Levels of hazard warnings	1
1.2 Staff qualification	1
1.3 Basic safety rules	1
1.4 Electrical voltage	1
1.5 Safety and protective functions	2
1.6 Electromagnetic radiation	2
1.7 Mechanical movement	2
1.8 Deflagration	2
1.9 Emission	2
1.10 Hot surface	2
1.11 Transport	2
1.12 Storage	3
1.13 Disposal	3
2. PROPER USE	3
3. TECHNICAL DATA	5
3.1 Product drawing	5
3.2 Nominal data	6
3.3 Data according to ErP directive	6
3.4 Technical features	6
3.5 Mounting data	6
3.6 Transport and storage conditions	6
3.7 Electromagnetic compatibility	6
4. CONNECTION AND START-UP	7
4.1 Connecting the mechanical system	7
4.2 Connecting the electrical system	7
4.3 Connection screen	9
4.4 Checking the connections	10
4.5 Switch on device	10
4.6 Switching off the device	10
5. INTEGRATED PROTECTIVE FUNCTIONS	10
6. MAINTENANCE, MALFUNCTIONS, POSSIBLE CAUSES AND REMEDIES	11
6.1 Cleaning	11
6.2 Safety test	11

1. SAFETY REGULATIONS AND NOTES

Please read these operating instructions carefully before starting to work with the device. Observe the following warnings to prevent malfunctions or physical damage to both property and people.

These operating instructions are to be regarded as part of this device. If the device is sold or transferred, the operating instructions must accompany it.

These operating instructions may be duplicated and forwarded for information about potential dangers and their prevention.

1.1 Levels of hazard warnings

These operating instructions use the following hazard levels to indicate potentially hazardous situations and important safety regulations:



DANGER

Indicates an imminently hazardous situation which, if not avoided, will result in death or serious injury. Compliance with the measures is mandatory.

WARNING

Indicates a potentially hazardous situation which, if not avoided, could result in death or serious injury. Exercise extreme caution while working.

CAUTION

Indicates a potentially hazardous situation which, if not avoided, may result in minor or moderate injury or damage of property.

NOTE

A potentially harmful situation can occur and, if not avoided, can lead to property damage.

1.2 Staff qualification

Only specialised electrical personnel may install the device, perform the test run and work on the electrical system.

Only trained and authorised specialist personnel are permitted to transport, unpack, assemble, operate or maintain the device, or to use it in any other manner.

1.3 Basic safety rules

Any safety hazards stemming from the device must be re-evaluated once it is installed in the end device.

Observe the following when working on the unit:

- ⇒ Do not make any modifications, additions or conversions to the device without the approval of ebm-papst.

1.4 Electrical voltage

- ⇒ Check the electrical equipment of the device at regular intervals, refer to chapter 6.2 Safety test.

- ⇒ Replace loose connections and defective cables immediately.



DANGER

Electrical load on the device

Risk of electric shock

- Stand on a rubber mat if you are working on an electrically charged device.

WARNING

Terminals and connections have voltage even with a unit that is shut off

Electric shock

- Wait five minutes after disconnecting the voltage at all poles before opening the device.

CAUTION

In the event of failure, there is electric voltage at the rotor and impeller

The rotor and impeller are base insulated.

→ Do not touch the rotor and impeller once they are installed.

CAUTION

If control voltage is applied or a speed setpoint is stored, the motor automatically restarts, e.g. after a power failure.

Danger of injury

- Keep out of the danger zone of the device.
- When working on the device, switch off the mains supply voltage and secure the latter from being switched on again.
- Wait until the device stops.
- After working on the device, remove any used tools or other objects from the device.

1.5 Safety and protective functions**DANGER**

Missing safety device and non-functioning safety device

If there is no safety device, you could be seriously injured, for example by reaching into the running device with your hands.

- Operate the device only with a fixed and isolating safety protection and a fixed guard grille. The guard must withstand the kinetic energy of a fan blade detaching at maximum speed.
- The device is a built-in component. You, the owner/operator, are responsible for providing adequate protection for the device.
- Shut down the device immediately if you detect a missing or ineffective protective feature.

1.6 Electromagnetic radiation

Interference from electromagnetic radiation is possible, e.g. in conjunction with open and closed-loop control devices.

If unacceptable emission intensities occur when the fan is installed, appropriate shielding measures have to be taken by the user.

NOTE

Electrical or electromagnetic interferences after integrating the device in installations on the customer's side.

- Verify that the entire setup is EMC compliant.

1.7 Mechanical movement**DANGER**

Danger of injury from open blower

Gas escapes. When the blower is open, you come into contact with rotating and electrically live parts. Escaping gas may also cause explosions.

- Never open the blower.

WARNING

Rotating device

Long hair, loose items of clothing and jewellery could become entangled and pulled into the device. You could be injured.

- Do not wear any loose clothing or jewellery while working on rotating parts.
- Protect long hair by wearing a cap.

WARNING

Flying parts

Missing safety devices may cause fan blades to be ejected at high speeds, causing bodily harm.

- Take appropriate safety measures.
The safety devices must prevent contact with rotating parts and the printed circuit board.

1.8 Deflagration**DANGER**

Gas escapes through leaky housing after deflagration

Danger of injury

- After a deflagration, check that the housing of the gas blower is tightly sealed.
- Replace any gas blower with a leaky housing.

**DANGER**

Fire and deflagration hazard

The gas blower is not approved according to Ex protection guidelines. Rotating parts can scrape against stationary parts. This may cause sparks and chips. The surface temperature may rise, resulting in a fire.

- Check which hazards arise from installing, operating, servicing or disposing the gas blower in conjunction with your device.
Prevent these hazards.
Carry out all appropriate measures to this purpose.

1.9 Emission**WARNING**

Depending on the installation and operating conditions, a sound pressure level greater than 70 dB(A) may arise.

Danger of noise-induced hearing loss

- Take appropriate technical safety measures.
- Protect operating personnel with appropriate safety equipment, e.g. hearing protection.
- Also observe the requirements of local agencies.

1.10 Hot surface**CAUTION**

High temperature at the electronics enclosure

Danger of burn injuries

- Ensure that sufficient protection against accidental contact is provided.

1.11 Transport**NOTE**

Transport of blower

- Transport the blower in its original packaging only.
- Secure the blower so that it does not slip, e.g. by using a clamping strap.

1.12 Storage

- ⇒ Store the device, partially or fully assembled, in a dry and weatherproof manner in the original packing in a clean environment.
- ⇒ Protect the device from environmental impacts and dirt until the final installation.
- ⇒ We recommend storing the device for a maximum up to one year to guarantee proper operation and longest possible service life.
- ⇒ Even devices explicitly suited for outdoor use are to be stored as described prior to being commissioned.
- ⇒ Maintain the storage temperature, see chapter 3.6 Transport and storage conditions.

1.13 Disposal

When disposing of the device, please comply with all relevant requirements and regulations applicable in your country.

2. PROPER USE

The device is exclusively designed as a built-in device for moving air and gases according to its technical data.

Any other or secondary use is deemed improper and constitutes a misuse of the device.

Installations on the customer's side must meet the mechanical, thermal and service life-related stresses that can occur.

Proper use also includes:

- Moving a gas/air mixture in gas burners with H gas, L gas and liquid gas according to gas family 2 and 3 in accordance with the German DVGW (German Technical and Scientific Association for Gas and Water), worksheet 260, in a concentration of approx. 90 % air and 10 % gas, integrated into an overall system which is designed specifically for operation with this gas type.
- Moving air with a density ranging from 0.9 to 1.2 kg/m³.
- Minding the operating instructions.
- Using the device in accordance with the permitted ambient temperature, see chapter 3.6 Transport and storage conditions and chapter .
- Only using the device in stationary systems.
- Installing the device into an overall system for moving air/gas mixtures.
- Commissioning the built-in component only after installation in the customer unit.
- Operating the device with all protective features in place.

Improper use

Using the device in the following ways is particularly prohibited and may cause hazards:

- Operating the device with an imbalance, e.g. caused by dirt deposits or icing.
- Moving a medium that contains abrasive particles.
- Moving a highly corrosive medium.
- Moving a medium that contains dust pollution, e.g. suctioning off saw dust.
- Operating the gas blower in an environment that contains flammable gases or dust or combustible solids or fluids.
- Moving an air/gas mixture outside an overall system that fulfils the requirements described above.
- Using the blower as a safety component or for taking on safety-related functions.
- Operation in medical equipment with a life-sustaining or lifesaving function.
- Contact with materials that could damage blower parts, e.g. liquids during cleaning.
- Operation with completely or partially disassembled or modified protective features.
- Exposure to radiation which could damage blower parts, e.g. strong UV radiation.
- Operation with external vibrations.
- Operating the device in an explosive atmosphere.
- Operation with completely or partially disassembled or modified protective features.

- In addition, all application options that are not listed under proper use.



3. TECHNICAL DATA

3.1 Product drawing

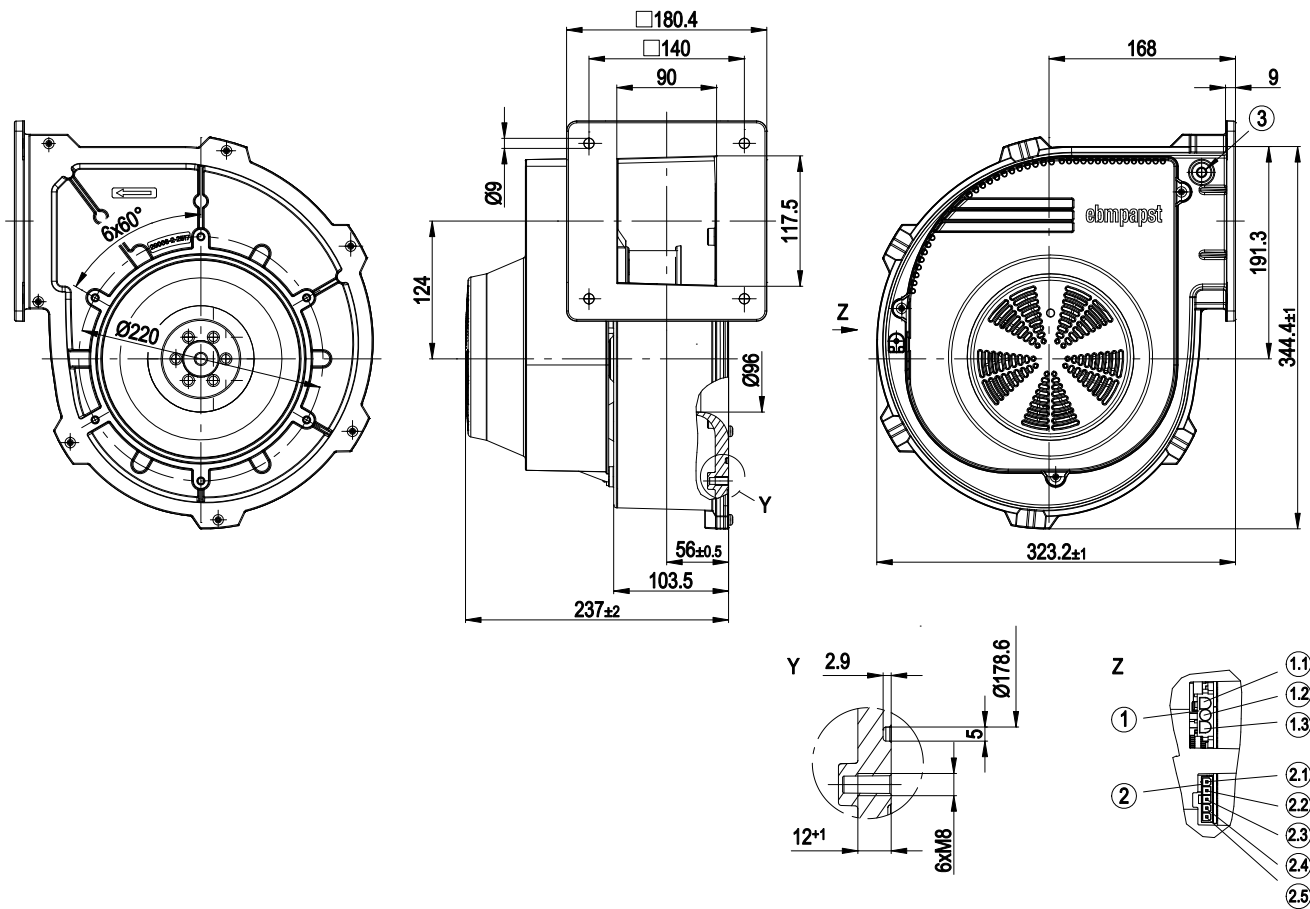

All measures have the unit mm.

Y	Detail Y
Z	View Z / plug assignment
1	3-pole strip to fit mating connector (not included in standard scope of delivery) Tyco No. 350766-1, female connector Tyco No. 926884-1
1.1	L
1.2	N
1.3	PE
2	5-pole strip to fit mating connector (not included in standard scope of delivery) Molex No. 39-01-4050, female connector Molex No. 39-00-0059
2.1	+
2.2	Speed monitoring
2.3	0-10 VDC
2.4	PWM input
2.5	-
3	Pressure tap optionally available



You can control the blower either via the 0-10 VDC input or the PWM input. Note: Inputs cannot be used simultaneously.

3.2 Nominal data

Motor	M3G084-DF
Phase	1~
Nominal voltage / VAC	230
Nominal voltage range / VAC	208 .. 240
Frequency / Hz	50/60
Type of data definition	ml
Speed / min ⁻¹	6100
Power input / W	890
Current draw / A	4.3 @ 208 V
Min. ambient temperature / °C	-20
Max. ambient temperature / °C	50
Min. temp. of flow medium / °C	0
Max. temp. of flow medium / °C	50

ml = max. load · me = max. efficiency · fa = running at free air
cs = customer specs · cu = customer unit

Subject to alterations

3.3 Data according to ErP directive

Installation category	A
Efficiency category	Static
Variable speed drive	Yes
Specific ratio*	1.02

* Specific ratio = $1 + p_{is} / 100\,000\text{ Pa}$

	Actual	Request 2013	Request 2015
Overall efficiency η_{es}	51.7	46.5	49.5
Efficiency grade N	63.2	58	61
Power input P_{ed} / kW	0.81		
Air flow q_v / m ³ /h	610		
Pressure increase total p_{sf} / Pa	2291		
Speed n / min ⁻¹	6075		

Data established at point of optimum efficiency

3.4 Technical features

Mass	9.2 kg
Size	200 mm
Surface of rotor	Coated in black
Material of protective cover	Polyflam RPP 374-ND CS1 (UL 97-V0)
Material of impeller	Aluminium sheet
Housing material	Die-cast aluminium
Number of blades	7
Direction of rotation	Clockwise, seen on rotor
Type of protection	IP 20
Insulation class	"B"
Mounting position	any

Condensate discharge holes	Rotor-side
Operation mode	S1
Motor bearing	Ball bearing
Technical features	- Tach output - Over-temperature-protected electronics / motor - PFC, active - Motor current limit - Line undervoltage / phase failure detection - PWM control input - Control input 0-10 V
Touch current acc. IEC 60990 (measuring network Fig. 4, TN system)	$\leq 3.5\text{ mA}$
Electrical leads	With plug
Motor protection	Locked-rotor protection
Protection class	I (if protective earth is connected by customer)
Approval	CSA C22.2 Nr.113; UL 507



For cyclic speed loads, note that the rotating parts of the device are designed for maximum one million load cycles. If you have specific questions, contact ebm-papst for support.

3.5 Mounting data

For depth of screw, see chapter 3.1 Product drawing

⇒ Secure the mounting screws against accidentally coming loose (e.g. by using self-locking screws).

Strength class for mounting screws	8.8
------------------------------------	-----

You can obtain additional mounting data from the product drawing if necessary.

3.6 Transport and storage conditions

⇒ Use the device in accordance with its protection type.

Max. permissible ambient motor temp. (transp./ storage)	+80 °C
Min. permissible ambient motor temp. (transp./storage)	-40 °C

3.7 Electromagnetic compatibility

EMC interference immunity	Acc. to EN 61000-6-2 (industrial environment)
EMC harmonics	Acc. to EN 61000-3-2/3
EMC interference emission	Acc. to EN 61000-6-4 (industrial environment)



4. CONNECTION AND START-UP

4.1 Connecting the mechanical system



DANGER

Gas leaking from improperly sealed housing

Risk of fatal injury

- Prior to commissioning, check that the housing of the gas blower is pressure-tight. When doing so, close the intake and exhaust opening and the shaft opening.
- In addition, check that rotating parts do not scrape against stationary parts.



DANGER

Leaks may occur.

As a result of design necessities, the gas blower is not tightly sealed, e.g. at the shaft opening. This may cause leaks during operation. Deflagrations may also cause long-term damage or deformation of the housing, which can result in leaks. An air/gas mixture may accumulate outside of the gas blower. The blower may explode. You could be severely injured.

- Check which hazards arise from installing, operating, servicing or disposing of the gas blower in conjunction with your device. Prevent these hazards. Carry out all appropriate measures to this purpose.



CAUTION

Cutting and crushing hazard when removing the blower from the packaging



- Carefully remove the blower from its packaging, only touching the housing. Make sure to avoid any shock.
- Wear safety shoes and cut-resistant safety gloves.

- ⇒ Check the device for transport damage. Damaged devices must no longer be installed.
- ⇒ Install the undamaged device according to your application.

4.2 Connecting the electrical system



DANGER

Electric voltage on the device

Electric shock

- Always install a protective earth first.
- Check the protective earth.



DANGER

Incorrect insulation

Risk of fatal injury from electric shock

- Use only cables that meet the specified installation requirements for voltage, current, insulation material, load etc.
- Route cables such that they cannot be touched by any rotating parts.



DANGER

Electrical load (>50 µC) between mains wire and protective earth connection after switching of the supply when switching multiple devices in parallel.

Electric shock, risk of injury

- Make sure that sufficient protection against accidental contact is provided. Before working on the electrical connection, the connections to the mains supply and PE must be shorted.

CAUTION

Electrical voltage

The device is a built-in component and features no electrically isolating switch.

- Connect the device only to circuits that can be switched off using an all-pole disconnecting switch.
- When working on the device, you must switch off the system/machine in which the device is installed and secure it from being switched on again.

NOTE

Water penetration into leads or wires

Water enters at the cable end on the customers side and can damage the device.

- Make sure that the cable end is connected in a dry environment.



The control voltage circuit is not electrically isolated. Connect the device only to circuits that can be switched off using an all-pole disconnecting switch.

4.2.1 Prerequisites

- ⇒ Check whether the data on the type plate agree with the connection data.
- ⇒ Before connecting the device, ensure that the supply voltage matches the operating voltage of the device.
- ⇒ Only use cables designed for current according to the type plate. For determining the cross-section, follow the basic principles in accordance with EN 61800-5-1. The protective earth must have a cross-section equal to or greater than the outer conductor cross-section. We recommend the use of 105°C cables. Ensure that the minimum cable cross-section is at least AWG26/0.13 mm².

4.2.2 Idle current



Because of the EMC filter integrated for compliance with EMC limits (interference emission and interference immunity), idle currents in the mains cable can be measured even when the motor is at a standstill and the mains voltage is switched on.

- The values lie in a range of typical < 250 mA.
- The effective power in this operating state (readiness for operation) is simultaneously at typical < 4 W.

4.2.3 Residual current operated device



Only universal (type B or B+) RCD protective devices are permitted. Like frequency inverters, RCD protective devices cannot provide personal safety while operating the device. When switching on the power supply of the device, pulsed charge currents from the capacitors in the integrated EMC filter can lead to the RCD protective devices triggering without delay. We recommend residual current devices with a trigger threshold of 300 mA and delayed triggering (super-resistant, characteristic K).

4.2.4 Locked-rotor protection



Due to the locked-rotor protection, the start-up current (LRA) is equal to or less than the nominal current (FLA).



4.3 Connection screen

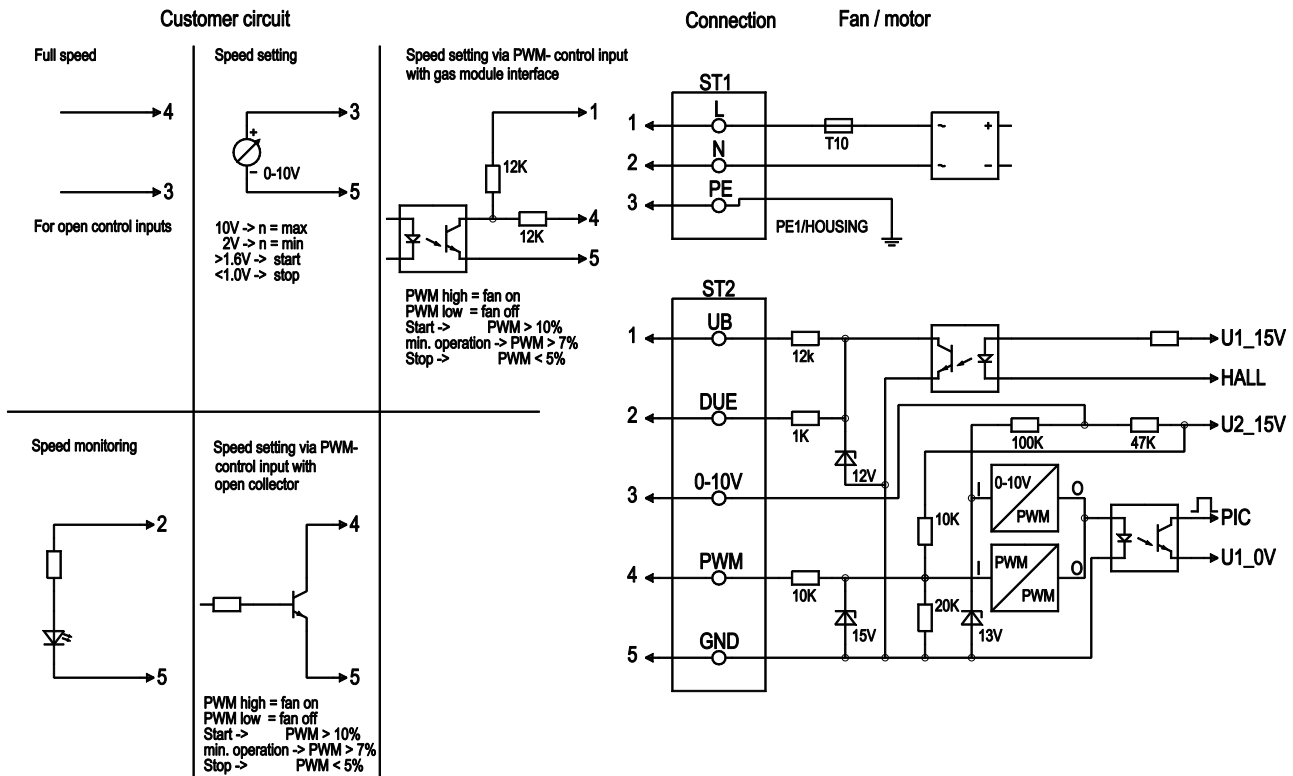

No.	Pin	Signal	Function / assignment
ST1	1; 2; 3	L; N; PE	Power supply 230 VAC, 50 - 60 Hz, phase, neutral, protective earth
ST2	1	UB	External voltage 16 - 45 VDC, residual ripple +/- 3.5%, SELV
ST2	2	Tach	Speed monitoring, 3 pulses per revolution, SELV
ST2	3	0 - 10 V	Control input 0 - 10 V, impedance 100k, SELV
ST2	4	PWM	Control input PWM, 1 - 6 kHz, SELV
ST2	5	GND	GND - Connection for control interface, SELV

4.4 Checking the connections

- ⇒ Make sure that the power is off (all phases).
- ⇒ Secure it from being switched on again.
- ⇒ Check that the mating connector is correctly locked into the panel connector.
- ⇒ Check that the mating connector is correctly crimped to the connection line.

4.5 Switch on device



WARNING
Hot motor housing
 Fire hazard

- Ensure that no combustible or flammable materials are located close to the blower.
- ⇒ Inspect the device for visible external damage and the proper function of the protective features before switching it on.
- ⇒ Check the air flow paths of the fan for foreign objects and remove any that are found.
- ⇒ Apply 0 VDC to the 0-10 V control input (if you are using the control input)
- ⇒ Apply 0 % PWM to the PWM control input (if you are using the PWM control input)
- ⇒ Apply the nominal voltage to the voltage supply.
- ⇒ Start the device by changing the input signal.

4.6 Switching off the device

Switching off the device during operation:

- ⇒ Switch on the device via the control input.
- ⇒ Do not switch the motor (e.g. in cyclic operation) on and off via power supply.

Switching off the device for maintenance work:

- ⇒ Switch on the device via the control input.
- ⇒ Do not switch the motor (e.g. in cyclic operation) on and off via power supply.
- ⇒ Disconnect the device from the supply voltage.
- ⇒ When disconnecting, be sure to disconnect the earth wire connection last.

5. INTEGRATED PROTECTIVE FUNCTIONS

The integrated protective functions cause the motor to switch off automatically in case of faults described in the table.

Malfunctions	Description / Function of safety feature
Rotor position detection error	An automatic restart occurs.
Locked rotor	⇒ After the blockage is removed, the motor restarts automatically.
Line under-voltage (mains input voltage outside of permitted nominal voltage)	⇒ If the mains supply voltage returns to permitted values, the motor restarts automatically.

6. MAINTENANCE, MALFUNCTIONS, POSSIBLE CAUSES AND REMEDIES

Do not perform any repairs on your device. Return the device to ebmpapst for repair or replacement.

WARNING

Terminals and connections have voltage even with a unit that is shut off

Electric shock

→ Wait five minutes after disconnecting the voltage at all poles before opening the device.

CAUTION

If the control signal of a blower that is connected to the power system is removed, the motor can restart automatically.

Danger of injury

→ When working on the blower, switch off the mains supply voltage and secure it from being switched on again.

→ Wait until the device stops.

CAUTION

Electrical load after device is switched off

Electric shock in case of contact

→ Wait for five minutes after disconnecting the voltage at all poles before touching the unit.

CAUTION

If control voltage is applied or a speed setpoint is stored, the motor automatically restarts, e.g. after a power failure.

Danger of injury

→ Keep out of the danger zone of the device.

→ When working on the device, switch off the mains supply voltage and secure the latter from being switched on again.

→ Wait until the device stops.

→ After working on the device, remove any used tools or other objects from the device.



If the blower remains out of use for some time, e.g. when in storage, we recommend switching the blower on for at least 2 hours to allow any condensate to evaporate and to move the bearings.

Malfunction/error	Possible cause	Possible remedy
Impeller running roughly	Imbalance in rotating parts	Clean the device; if imbalance is still evident after cleaning, replace the device. If you have attached any weight clips during cleaning, make sure to remove them afterwards.
Motor does not turn	Mechanical blockage	Switch off, de-energise, and remove mechanical blockage.

	Mains supply voltage faulty	Check mains supply voltage, restore power supply, apply control signal.
	Faulty connection	De-energise, correct connection, see connection diagram.
Overtemperature of electronics/motor	Insufficient cooling	Improve cooling. Let the device cool down. To reset the error message, switch off the mains supply voltage for a min. of 25 s and switch it on again.
	Ambient temperature too high	Reduce the ambient temperature. Reset by reducing control input to 0.
	Unacceptable operating point	Correct the operating point. Let the device cool down.
Deflagration	Leakage of the handled air/gas mixture	Check for leaks; replace blower if not properly sealed



If you have any other problems, contact ebmpapst.

6.1 Cleaning

NOTE

The device does not need to be cleaned.

6.2 Safety test

NOTE

High-voltage test

The integrated EMC filter contains Y capacitors. Therefore, the trigger current is exceeded when AC testing voltage is applied.

→ Test the device with DC voltage when you carry out the high-voltage test required by law. The voltage to be used corresponds to the peak value of the AC voltage required by the standard.

What has to be tested?	How to test?	Frequency	Which measure?
Check the protective casing against accidental contact for damage and to ensure that it is intact	Visual inspection	At least every 6 months	Repair or replacement of the device

Check the device for damage to blades and housing	Visual inspection	At least every 6 months	Replacement of the device
Mounting the connection lines	Visual inspection	At least every 6 months	Fasten
Mounting of protective earth connection	Visual inspection	At least every 6 months	Fasten
Check the insulation of the wires for damage	Visual inspection	At least every 6 months	Replace wires
Condensate discharge holes for clogging, as necessary	Visual inspection	At least every 6 months	Open bore holes
Check the ball bearings to ensure they are quiet, can move easily and are free of play	Manual check by turning the rotor in shut-off state	At least every 6 months	Replace device in case of noise, difficulty of movement or clearance of the bearings