

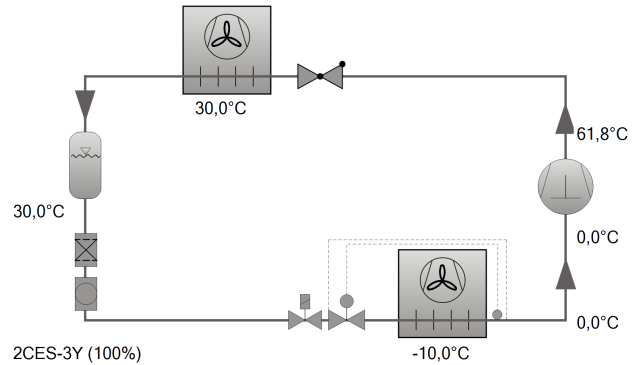

Selection: Semi-hermetic Reciprocating Compressors

Input Values

| | |
|---------------------------|------------------------------------|
| Compressor model | 2CES-3Y |
| Mode | Refrigeration and air conditioning |
| Refrigerant | R134a |
| Reference temperature | Dew point temp. |
| Evaporating SST | -10,00 °C |
| Condensing SDT | 30,0 °C |
| Liq. subc. (in condenser) | 0 K |
| Suct. gas superheat | 10,00 K |
| Operating mode | Auto |
| Power supply | 400V-3-50Hz |
| Capacity control | 100% |
| Useful superheat | 100% |



Result

| | |
|---------------------------------|--------------------|
| Compressor | 2CES-3Y-40S |
| Capacity steps | 100% |
| Cooling capacity | 6,00 kW |
| Cooling capacity * | 6,10 kW |
| Evaporator capacity | 6,00 kW |
| Power input | 1,78 kW |
| Current (400V) | 4,25 A |
| Voltage range | 380-420V |
| Condenser capacity | 7,78 kW |
| COP/EER | 3,37 |
| COP/EER * | 3,43 |
| Mass flow | 135,9 kg/h |
| Operating mode | Standard |
| Discharge gas temp. w/o cooling | 61,8 °C |



Tentative Data.

*Compressor performance data certified by ASERCOM (see T. Data/ Notes)

*According to EN12900 (20°C suction gas temp., 0K liquid subcooling)

Application Limits 100% 2CES-3

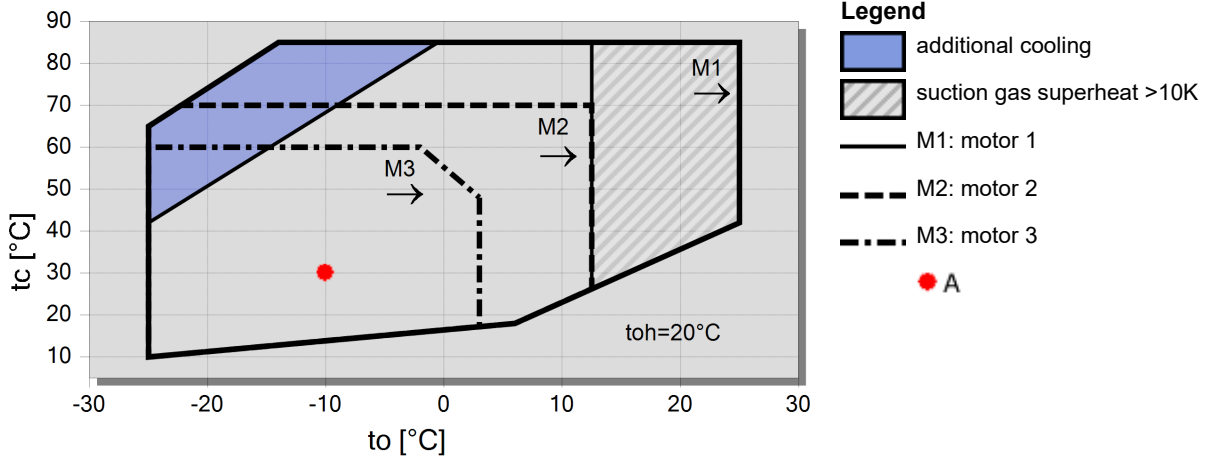

Legend

- additional cooling
- suction gas superheat >10K
- M1: motor 1
- - - M2: motor 2
- · - · M3: motor 3
- A



Technical Data: 2CES-3Y

Dimensions and Connections

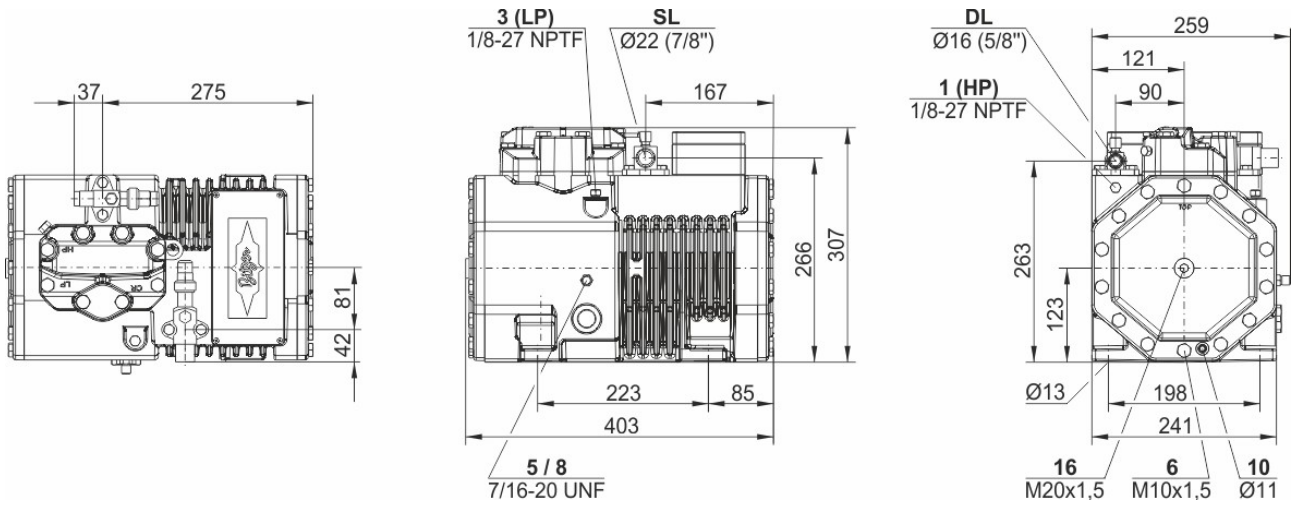



Technical Data

Technical Data

| | |
|--|--|
| Displacement (1450rpm 50Hz) | 16,24 m ³ /h |
| Displacement (1750rpm 60Hz) | 19,60 m ³ /h |
| No. of cylinder x bore x stroke | 2 x 55 mm x 39,3 mm |
| Weight | 76 kg |
| Max. pressure (LP/HP) | 19 / 32bar |
| Connection suction line | 22 mm - 7/8" |
| Connection discharge line | 16 mm - 5/8" |
| Oil type R134a/R407C/R404A/R507A/R407A/R407F | BSE32(Standard) R134a tc>70°C: BSE55 (Option) |
| Oil type R22 (R12/R502) | B5.2 (Option) |
| Oil type R1234yf | BSE32 (Standard) R1234yf tc>70°C : BSE55 (Option) |
| Oil type R1234ze | BSE55 (Standard) to>15°C: BSE85K (Option) tc>70°C: BSE85K (Option) |
| Oil type R454C/R455A | BSE32 (Standard) |
| Oil type R515B | BSE55 (Standard) to>15°C: BSE85K (Option) tc>70°C: BSE85K (Option) |

Motor data

| | |
|---------------------------------|-------------------|
| Motor version | 2 |
| Motor voltage (more on request) | 380-420V Y-3-50Hz |
| Max. operating current | 9.1 A |
| Starting current (Rotor locked) | 37.0 A |
| Max. power input | 5,0 kW |

Extent of delivery (standard)

| | |
|--------------------------|--------------------------------|
| Motor protection | SE-B3(Standard), SE-B2(Option) |
| Enclosure class | IP66 |
| Vibration dampers | Standard |
| Oil charge | 1,50 dm ³ |
| Discharge shut-off valve | Standard |
| Suction shut-off valve | Standard |

Available options

| | |
|----------------|-----------------------|
| Additional fan | Option |
| Oil heater | 0..120 W PTC (Option) |

Sound measurement

| | |
|--|-------------------|
| Sound power level (-10°C / 45°C) | 67,0 dB(A) @ 50Hz |
| Sound power level (-35°C / 40°C) | 70,0 dB(A) @ 50Hz |
| Sound pressure level @ 1m (-10°C / 45°C) | 59,0 dB(A) @ 50Hz |
| Sound pressure level @ 1m (-35°C / 40°C) | 62,0 dB(A) @ 50Hz |



Semi-hermetic Reciprocating Compressors

Motor 1 = e.g. 4TES-12 with 12 "HP", primary for air-conditioning (e.g. R22,R407C) and air-conditioning with R134a at high ambient temperatures.

Motor 2 = e.g. 4TES-9 with 8 "HP", universal Motor for medium and low temperature application (e.g. R404A, R507A, R407A, R407F) and air-conditioning with R134a

Motor 3 = e.g. 4TES-8, for medium temperature applications and R134a

For more information concerning the application range use the "Limits" button.

Operation modes 4VES-7 to 6FE-44 and 44JE-30 to 66FE-88 with R407F/R407A/R22

CIC = liquid injection with low temperature application, suction gas cooled motor.

ASERCOM certified performance data

The Association of European Refrigeration Component Manufacturers has implemented a procedure of certifying performance data. The high standard of these certifications is assured by:

- * plausibility tests of the data performed by experts.
- * regular measurements at independent institutes.

These high efforts result in the fact that only a limited number of compressors can be submitted. Due to this not all BITZER compressors are certified until now. Performance data of compressors which fulfil the strict requirements may carry the label "ASERCOM certified". In this software you will find the label at the respective compressors on the right side below the field "result" or in the print out of the performance data. All certified compressors and further information are listed on the homepage of ASERCOM.

Condensing capacity

The condensing capacity can be calculated with or without heat rejection. This option can be set in the menu Program Options. The heat rejection is constantly 5 % of the power consumption. The condensing capacity is to be found in the line Condensing cap. (with HR) resp. Condensing capacity.

Data for sound emission

Data based on 50 HZ application (IP-units 60 Hz) and R404A if not declared.

Sound pressure level: values based on free field area conditions with hemispherical sound emission in 1 meter distance.

General remarks regarding sound data

Listed sound data were measured under testing conditions in our laboratory. For this purpose the free-standing test sample is mounted on a solid foundation plate and the pipework is connected vibration-free to the largest extent possible. Suction and discharge lines are fixed in a flexible configuration, such that a transmission of vibrations to the environment can be largely excluded. In real installations considerable differences might be observed, compared to the measurements in the laboratory. The airborne sound emitted by the compressor can be reflected from surfaces of the system and this may increase the airborne sound level measured close to the compressor. Vibrations caused by the compressor are also transferred to the system by the compressor feet and piping depending on the damping ratio of the fixings. Thus, the vibrations can induce other components to such an extent that these components contribute to an increase in airborne sound emission. If required, the transfer of vibrations to the system can be minimized by suitable fixing and damping elements.